

Kinetico 4040s

OVERDRIVE[®]
ENHANCED

Non-Electric,
High Performance
Combination System



 **Kinetico**[®]
home water systems

Conditioned, Dechlorinated Water 24 Hours a Day, Every Day

Simple, Reliable and Economical Operation

Quad Tank Design Combines Two Systems Into One

Certified Performance

Installation and Service by Trained Water Treatment Professionals

What Makes The Kineticco Overdrive[®] Enhanced 4040s Different?

- 1. Non-Electric Operation.** Reliable. No timers or computers to set, adjust, repair or replace.
- 2. Metered, Demand Service.** Unlimited supply of clean, soft, dechlorinated water. Eliminates guesswork, water and regenerant waste, and hard water breakthrough.
- 3. Quad Tank System.** Separate carbon and resin tanks combine two systems into one. Continuous availability of clean, dechlorinated water. Saves money and space. Simplifies maintenance.
- 4. Overdrive Enhanced.** All tanks are in service simultaneously. Increases performance, efficiency, flow rate and media life.
- 5. High Flow Rate.** System keeps up with the conditioned water needs of today's demanding households.
- 6. Large Porting Size.** Perfectly suited for larger plumbing found in many homes. Up to 1 1/2 inch.
- 7. Efficient Hardness Removal.** Assures consistent and continuous clean, soft water. Saves money on soaps and cleaners. Protects plumbing and appliances.
- 8. Efficient Chlorine Reduction:** Carbon absorbs objectionable tastes and odors from chlorinated water. Improves the taste of water. Eliminates odors. Reduces drying of hair and skin from chlorine.
- 9. High Efficiency, Packed Resin Bed.** More efficient hardness removal. Conserves regenerant and water. Increases performance.
- 10. Efficient Use of Water and Regenerant.** Low water consumption. Less money spent on regenerant.
- 11. Corrosion-Resistant Valve and Tanks.** Long lasting. Can endure harsh environments.
- 12. Soft Water, Countercurrent Regeneration.** Increases product efficiency and water quality.
- 13. Automatic Operation.** Just add regenerant.
- 14. Outstanding Warranty.** Dependability, peace of mind.

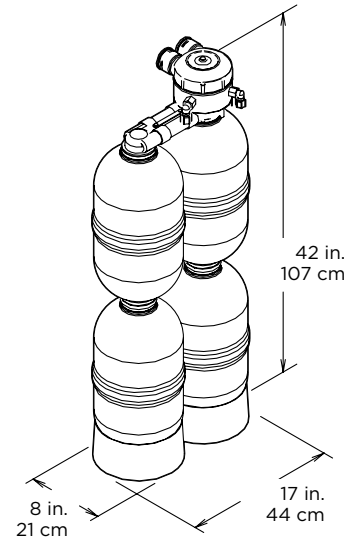

Brine Tank Options:

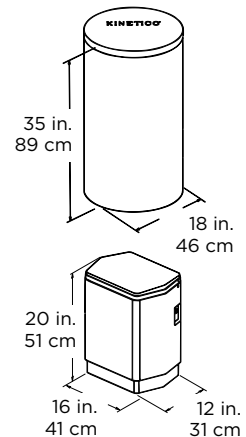

Third-Party Certification

The majority of Kineticco products are certified by third party labs such as NSF and WQA. To further ensure consumer confidence, several of our models are certified by two or more of these independent labs, which is unprecedented in the industry. For specific claims and certifying labs, refer to performance data sheets or consult your local Kineticco dealer.

* Information on the performance characteristics of Purefecta[®] can be found at www.epa.gov/etv or call 1.440.564.9111 for a copy of the ETV verification report. Use of the ETV name or logo does not imply approval or certification of this product nor does it make any explicit or implied warranties or guarantees as to product performance.

